

Make sure to read the **Rethink Dirt** and **Shocks: A Mystery No More** papers at www.hyperracing.com.

Part 1. How to achieve maximum traction.

Understanding Weight Transfer and Tire Efficiency

- **#1** Tire efficiency

The traction available from each tire is a function of how much weight is applied to it. More weight gives more traction, but the amount of increase in traction becomes less as more weight is applied. It diminishes. It is called tire efficiency and it looks like this:

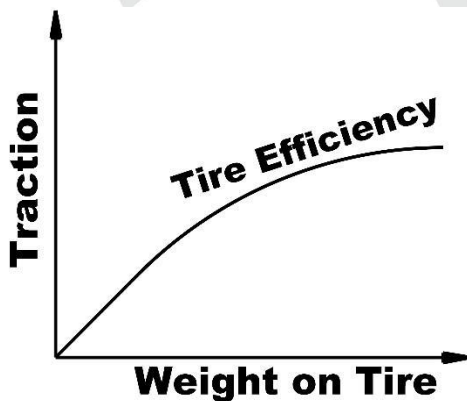

- **#2** Maximum traction

Two tires with 100 pounds each will get more traction than the same two tires with one having 50 and the other having 150 pounds. This is a fact derived from the tire efficiency principle.

Maximum Lateral traction (side to side) occurs when all 4 tires are equally loaded. This is because of Tire Efficiency. As stated in the weight transfer formula, a lower CGH (lower ride heights) will give greater lateral traction because it will transfer less weight while keeping the 4 tires more equally loaded.

Maximum Longitudinal traction (forward acceleration) occurs when the two rear tires are equally loaded and no weight is on the front tires. This assumes of course that it is a rear drive vehicle. As stated by the formula, a higher CGH will give greater longitudinal traction because more weight will transfer from the front to the rear.



Therefore, we can't have maximum lateral and longitudinal traction at the same time. When making an adjustment, you must first determine what you are asking the car to do. The adjustment will likely help one and hurt the other. Although both types of traction will benefit from the rear tires being more equally loaded.

- **#3** Total weight transfer

Here are the formulas that describe how much total weight transfers from left to the right (lateral) side acceleration, and how much total weight transfers from the front to the rear (longitudinal), forward acceleration.

$$\text{Longitudinal Weight Transfer} = \left(\frac{\text{Weight} \times \text{CGH}}{\text{Wheel Base}} \right) \times \text{Longitudinal G Force}$$

(front to back)

$$\text{Lateral Weight Transfer} = \left(\frac{\text{Weight} \times \text{CGH}}{\text{Track Width}} \right) \times \text{Lateral G Force}$$

(side to side)

These are the only factors that affect the total amount of weight transfer due to the lateral and longitudinal g-forces, nothing else matters. Many of our adjustments will affect the center of gravity height (CGH)

This is total weight transfer. Springs, shocks, and wheel offsets will determine to which corner the weight gets transferred.

- **#4** Roll Couple

Roll Couple determines which of the two tires the weight gets transferred to during lateral acceleration (side g-forces).

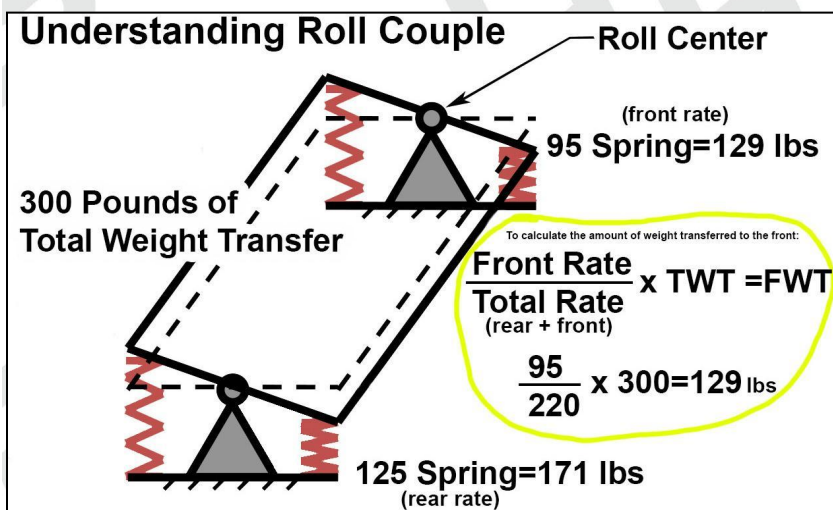



As we increase the right front spring rate, **more** weight will transfer to the right front and less to the right rear. The total weight transfer will remain the same.

A softer spring will transfer **less** weight to that corner of the car than a stiffer spring. Yes, the car will have more rear roll angle with a softer spring there, but it will be transferring less weight to the right rear. Notice I said more rear roll angle and not rolls more on the right rear? Because it doesn't roll more on the right rear although there is more rear roll.

This same concept of roll couple can be applied to the front to back roll, this is called pitch. Left and right rear spring rate will control which rear corner the longitudinal weight gets transferred to.

This is a simplified example as we really need to be looking at wheel rates and not spring rates directly. Wheel rate is a function of how far the wheel is from the spring (wheel offset from frame). But the concept is what is important to understand when making adjustments.

- **#5** Geometric vs elastic weight transfer

Weight transferred through the springs is called elastic weight transfer. Weight transferred through the mechanical suspension parts like the panhard bar or Jacob's ladder is called geometric weight transfer.

Not all the weight transfer goes through the springs. Some of the weight gets transferred through the mechanical parts of the suspension like the Jacob's Ladder or the panhard bar. The bad thing about geometric weight transfer is that it does not go through the springs and can cause a harsh ride and cause the car hop and or loose grip.

Roll center height will have a large influence on how much the car will roll and which corner the weight will get transferred to. It will not change how much total weight is transferred. It will change how much lateral weight is transferred to the RF and the RR. The formulas get a bit more complex, but just know that as you raise the roll center at either the front or the rear, it will make that end transfer more of the total lateral weight.

You can figure out what percentage of weight is geometric by dividing the distance from the ground to the roll center and dividing it by the distance from the ground to the CG (see the diagram below).

Elastic weight transfer acts like a super stiff spring and the weight is transferred immediately where the elastic weight is transferred more slowly.

HyperTM RACING

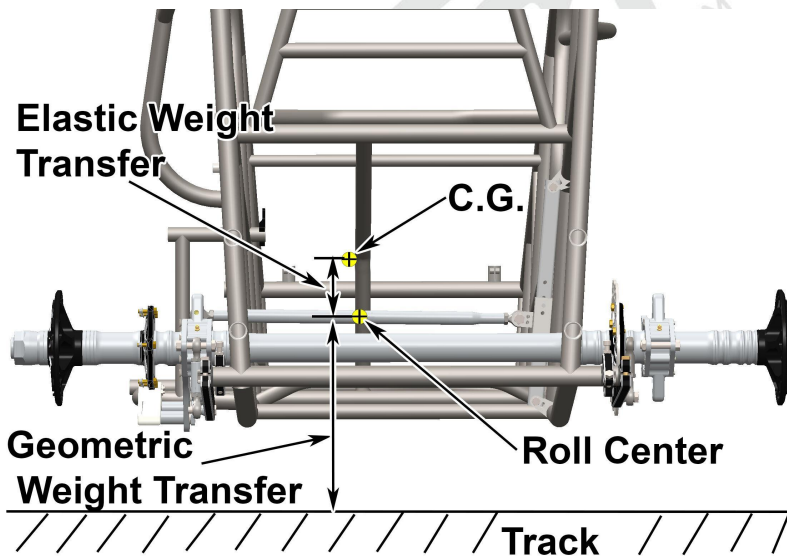

This same geometric transfer happens in the longitudinal direction as well. It again is a function of the roll center front to back, which is called the pitch center and its distance relative to the CGH. Pitch center is determined by the rear end geometry. For example, a wishbone has a very high pitch center when compared to the Z-link suspension.

Conclusion:

- As we increase the weight transfer from left to right, the car will get less lateral traction. As we increase weight transfer from front to back the car will get more traction when accelerating forward.
- For both lateral and longitudinal traction, as we keep the rear tires more equally loaded, traction will increase.
- As we increase the right front spring rate, the rear tires will be more equally loaded.
- Raising the rear roll center will transfer more of the total transferred weight to the rear, but the car will roll less. Lowering it will make the car roll more but transfer less weight to the rear. So lowering the rear roll center will create rear traction.

Primary Adjustments

Almost all suspension adjustments affect one of the 5 principles listed in Level 1. To figure out what handling characteristic the adjustment is going to change, consider its effect on the principle in Level I call these Primary Factors because all other adjustments will directly affect one of these factors or adjustments. They are not more important than the other factors, just that they are the direct cause of the change.

- CGH (generally measured as ride heights)
- Total weight of the car
- Track width (wheel offsets)



- Wheel base
- Wheel rate (a direct function of spring rate and wheel offsets)
- Shock dampening direct loading on corner weight
 - If we add **more rebound** dampening force to a shock on a particular corner of a car it will cause that corner of the car to have **less** weight on it when that shock is in the rebound state.
 - Conversely If we add **more compression** dampening force to a shock on a particular corner of a car it will cause that corner of the car to have **more weight** on it when that shock is in the compression state.
 - This probably should be a secondary adjustment for the rear shocks as it has to be multiplied by the motion ratio determined by the mounting point on the rear arm.
- Static Corner Weights
 - Static weight is very minute compared to the amount of weight that is transferred through g-forces and shock dampening forces
- Aerodynamic loading (for winged car adjustments)
 - How is the wing adjustment changing the tire loading? Consider the airfoil and the sideboards.
- Roll center heights
- Non Level 1 related primary factors: (these have direct effects on the car, but are not related to Level 1)
 - Stagger
 - Tire Compound
 - Tire Grooves
 - Tire Contact patch size
 - Air Pressure
 - Camber
 - Tire width, side wall stiffness
 - Tire diameter
 - Wheel Alignment

Secondary Adjustments

These adjustments will affect one of the primary adjustments in Level 2.

- Spring Rates (torsion arm length, arm angle, bar size, coil size)
- Shock dampening effect on CGH (stiffer compression shocks will hold the car higher at times)
- Shock Gas Pressure
- Shock Angles (affects shock dampening rate (\cos^2 of angle * dampening force))
- Tire Pressures effect on CGH and the tires inherent spring rate.
- King Pin inclination, loads LR and RF when counter steer
- Wings effect on total W, CGH, corner weights (tire Efficiency)
- Ride heights/Block size/Turns in torsion stops or coil over nuts
- Chain Force
- All suspension mounting locations (roll center, pitch center, etc)

- Bearing carrier and shock mounting locations, distance from wheel
- Other Tire Factors: Inherit spring rate and side wall stiffness, we have no control over these, but they do vary a lot between manufacturers.

Part 2. Understand what your car is doing on the track.

I can't possibly give you a chart of what adjustments to make for every scenario. There are too many variables and too many situations. Maybe a computer program referencing a large database would work. If you understand the principles and the different levels mentioned above, you will be able to think your way through what adjustment might work for what you are trying to achieve.

I think one of the hardest things about trying to get your car faster is trying to figure out what exactly you want your car to do. If you can figure that out, a solution can be found, but only if you know what you really want. Many times racers want too much traction or too much of one thing. Be careful.

The diagram below attempts to divide the corner up into phases that best describe where adjustments will affect the handling of the car. Depending on track size, shape, and conditions, these phases of the turn can vary widely.

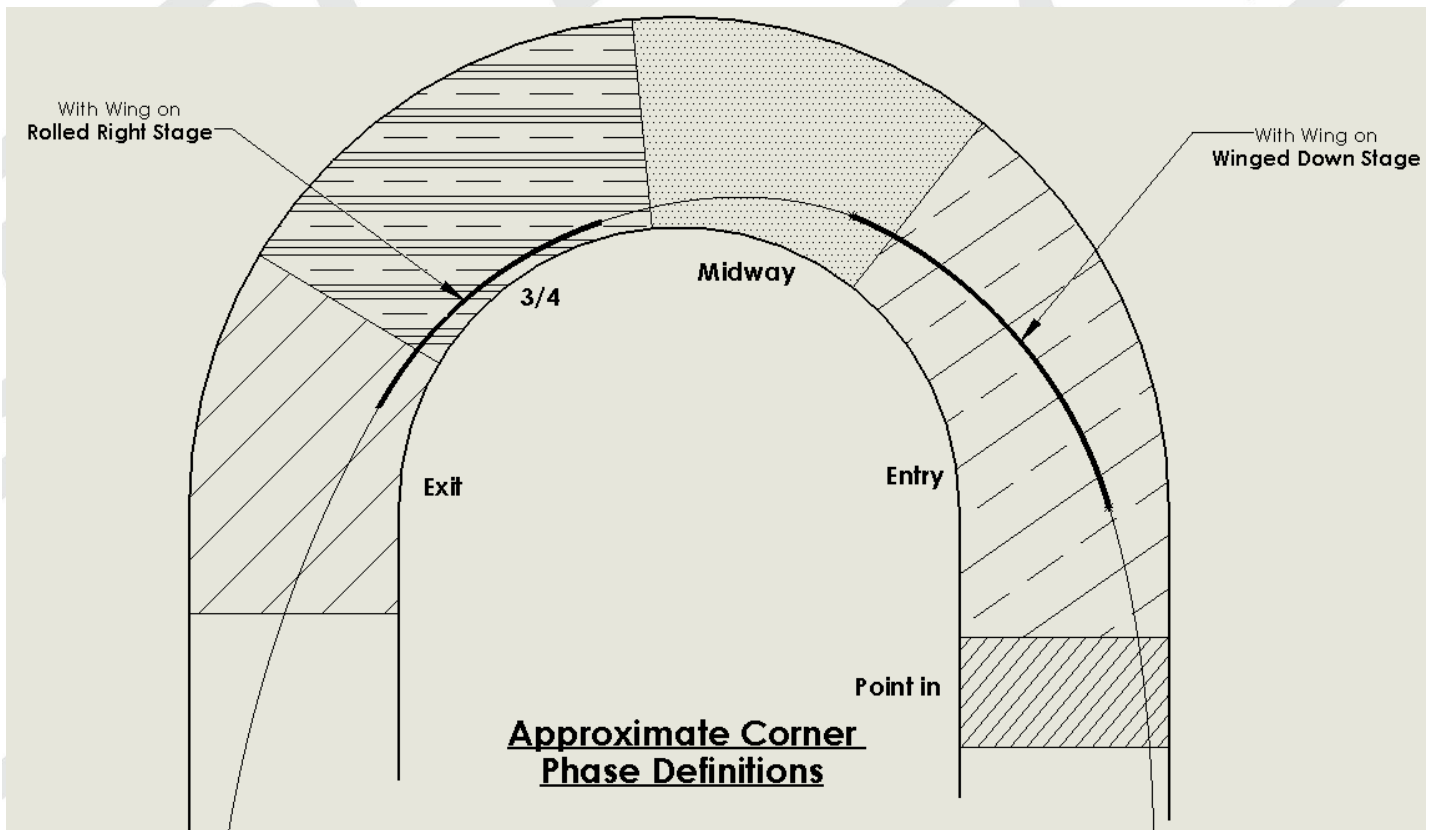



The adjustments we make to help the car in these phases of the turn can be drastically different depending on if the car is winged or wingless.

A winged car adds two stages to the corner definitions. I call the first the **Winged Down Stage**, this is when the car rolls to the left due to the wing sideboards. This happens on corner entry. The bigger the track the longer the winged down stage will be.

The way we adjust the cars right side springs to get the balanced roll couple for wingless, is going to be applied to the left side springs and shocks to adjust the car during the winged down phase.

The second is the **Rolled Right Stage**, which occurs when the car slows enough that the lateral g-force on the car is greater than the side force generated by the wing panels. As a driver, you need to pay attention to how the car is working when it is winged left and rolled right and make your changes accordingly. The length of the winged down stage of the turn is different for each size and shape track, and it also changes during the night as the track goes slick. A track with tighter turns relative to the length of the straight will have more winged left effect, tracks that are larger will also have more winged left effect, and as the track gets slicker there is more winged down phase.

The **Point In** phase is very short. It is that phase of the turn where the driver first turns the car to the left. Once the car points in, the driver will need to start counter steering. If the driver turns the car, but the car does not react, a push can occur for a small part or the whole way through the turn. Generally, a push during point in is caused by not enough weight on the right front. A car will never be loose in this phase.

If tight, add more static RF weight by adding turns to the RF, or take turns out of LF. Sometimes too much RF offset can cause this as well. A stiffer RF spring can help. Increasing wing angle can cause the car to do this as it causes the LR spring to compress unloading the RF, adding RF/LR static weight or increasing the LR spring rate will help.

Corner Entry is the phase of the turn where the car is in transition the most.

In wingless racing, this is the phase where the car is rolling from the left side to the right. If you start out with too much static LR weight, the car will be loose on entry until the weight transfers to the RR where the tires will be equally loaded and achieve maximum lateral traction. The slicker the track, the longer it takes the weight to transfer and the less amount of total weight transfers due to the reduced g-force (reference the formula).

Right side springs, right side shock compression, left side rebound, and right side wheel offsets are factors that matter.



In winged racing, this is where the very violent action of the car winging down left occurs.

Pay attention to the car bottoming out on the LR during this phase. You may need to increase the LR shock high-speed compression, increase the LR spring rate, or raise the LR ride height. LF compression, LF spring rate, LF & LR offset will all be big players in this phase with the wing on. Wing post height and sideboard location also matters.

The **Mid Way Phase** is where the driver is getting back on the throttle or is back at full throttle. Lateral g-force is greatest here, the car is already rolled right, the cars stance is pretty much set. Longitudinal traction becomes a bigger factor in this phase.

Ride heights and corner weights are important, front rebound also plays a roll. Shock dampening in both rebound and compression can matter here, as the shocks never stop moving.

3/4 Phase and the **Corner Exit Phase** are very close to the same; there is more lateral g-force at 3/4. The driver plays a big role in 3/4 since they are going to try to find bite in the track. Handling characteristics will change a ton depending on how well the driver can keep the car in the bite and how much they are asking his car to turn vs. accelerate forward.

Near the end of the 3/4 Phase is also where the car begins to roll left and back to neutral again as the lateral g's decrease.

During this transition the left side compression and right side rebound will have an effect.

CGH (ride heights) and rear weight bias are everything on corner exit. More rear weight and a higher car will always yield more longitudinal traction (forward bite). But don't forget all the factors that play into CGH dynamically. Anti-squat, spring rates, shock rates (in both rebound and compression), seat height, engine mount height, tank tail mounting, etc. They are all factors.

With the wing on, wing angle plays its biggest part in 3/4 and corner exit. More wing angle will get more weight on the rear of the car.

Straightaway Phase Torque gets it off the corner, horsepower gets it in!



How to find the Center Gravity Height (CGH) of your chassis.

You will need 4 digital scales and a way to raise the rear axle up about 31".

This should be done with the driver in the car and the car setup at race ready condition with 2-3 gallons of fuel in it. Tire pressures set.

Scale your car on all 4 wheels. Record all the numbers.

Now raise the rear of the car 31-1/2" for a 63" wheel base, 31" for a 62" wheel base or 30" for a 60" wheel base. This is the height you raised the rear axle at the center line. For example: if the rear axle is 9" to start with, raise it an additional 31" (40" from the ground). This will put the car at a 30-degree angle. You can use a different angle; just take the tangent of whatever angle you choose. Record the total weight of the front axle.

Now you have all the information to calculate your center of gravity weight!

Here is the formula:

$$CGH = \frac{(WB \times (FW1 - FW2))}{(W \times \tan\theta)}$$

WB=Wheel Base (center of front axle to center of rear axle). Should be between 59" and 63" depending on your car.

FW1 = Weight of the front axle (right front weight + left front weight) when the car is on the ground.

FW2 = Weight of the front axle when the rear axle is raised in the air

W= Total Weight of the chassis

$\tan\theta$ = tangent of the angle (try to get it to 30 degrees) (.57735)